

# TYRE CURING BLADDER

Products 2020/2021



# EXTREME ENDURANCE

You can rely on our expertise in the automotive industry. We produce tyre curing bladders that consistently stay in shape.

## » MANY SURFACES, EVERY ADVANTAGE

HKL produces tyre curing bladders in different surface variants. The structure allows for ideal ventilation during the vulcanisation process. Talk to us to find the perfect choice for your tyre.

### » OPTIMISED WALL THICKNESS

Our state-of-the-art injection procedure extends the material's life cycle, at the same time producing very thin tyre walls. As a result, your curing cycle times in the tyre press will be significantly reduced – for reduced energy and more efficiency in your production process.

### SMALL PEBBLE



### SPIDERWEB



### GROOVE

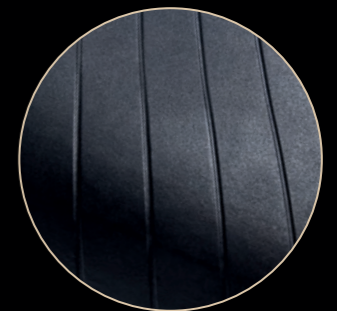

**BOM / KRUPP**

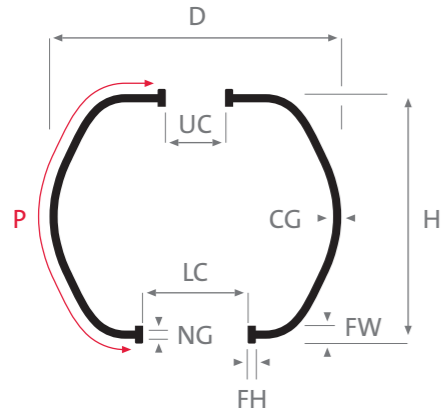

*Bom / Krupp*

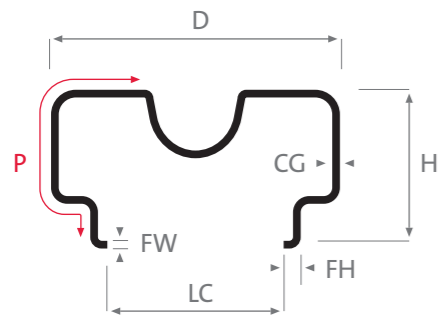

*Autoform*

**AUTOFORM**

Designation	Outer Diameter	Periphery	I.D. Upper Clamp	I.D. Lower Clamp	Height	Center Gauge	Neck Gauge	Foot Width	Foot Height	Process	Surface, Venting
	D / mm	P / mm	UC / mm	LC / mm	H / mm	CG / mm	NG / mm	FW / mm	FH / mm		
270 x 475	270 – 290	475	330	270	270	4,5	6,0	18	10	CM	Groove
295 x 475	270 – 290	475	355	270	295	4,5	6,0	18	10	CM	Groove
320 x 475	270 – 290	475	380	270	320	4,5	6,0	18	10	CM	Groove
345 x 475	270 – 290	475	405	270	345	4,5	6,0	18	10	CM	Groove
510 x 503	170 – 225	510	479	170	232	5,5	9,0	23	11	CM	Groove
431 x 515	270 – 290	515	505	270	431	4,8	6,0	18	10	IM	Spiderweb
471 x 515	270 – 290	515	544	270	471	4,8	6,0	18	10	IM	Spiderweb
541 x 515	270 – 290	515	615	270	541	6,0	6,0	18	10	CM	Groove
520 x 570	170 – 225	520	548	170	225	4,5	9,0	23	11	IM	Spiderweb
390 x 530	320 – 340	530	473	320	396	4,8	6,0	20	12	IM	Small Pebble
410 x 530	320 – 340	530	493	320	416	4,8	6,0	20	12	IM	Small Pebble
430 x 530	320 – 340	530	513	320	436	4,8	6,0	20	12	IM	Small Pebble
450 x 530	320 – 340	530	533	320	456	4,8	6,0	20	12	IM	Small Pebble
470 x 530	320 – 340	530	553	320	476	4,8	6,0	20	12	IM	Small Pebble
490 x 530	320 – 340	530	573	320	496	4,8	6,0	20	12	IM	Small Pebble
300 x 540	270 – 290	540	390	270	300	4,5	6,0	18	10	CM	Groove
330 x 540	270 – 290	540	422	270	330	4,5	6,0	18	10	CM	Groove
360 x 540	270 – 290	540	451	270	360	4,8	6,0	18	10	IM	Small Pebble
400 x 540	270 – 290	540	490	270	400	4,8	6,0	18	10	IM	Small Pebble
543 x 543	170 – 225	543	519	170	225	4,5	9,0	23	11	IM	Spiderweb
543 x 570	170 – 225	543	546	170	225	4,5	9,0	23	11	IM	Spiderweb
543 x 589	170 – 225	543	565	170	225	4,5	9,0	23	11	IM	Spiderweb
543 x 630	170 – 225	543	606	170	225	4,5	9,0	23	11	IM	Spiderweb
578 x 638	170 – 225	578	640	170	225	4,8	9,0	23	11	IM	Spiderweb
14 x 300 x 550	550	550	/	330	350	4,8	/	14,5	15	IM	Spiderweb

**MOTORCYCLE**

Designation	Outer Diameter	Periphery	I.D. Upper Clamp	I.D. Lower Clamp	Height	Center Gauge	Neck Gauge	Process	Surface, Venting		
	D / mm	P / mm	UC / mm	LC / mm	H / mm	CG / mm	NG / mm				
488 x 181	170 – 225	488	337	170	181	4,4	9,0	23	11	CM	Groove
525 x 171	170 – 225	525	356	170	171	4,0	9,0	23	11	CM	Groove
542 x 196	170 – 225	542	390	170	196	4,4	9,0	23	11	CM	Groove
556 x 200	170 – 225	556	404	170	200	4,4	9,0	23	11	CM	Groove
570 x 206	170 – 225	570	406	170	206	4,0	9,0	23	11	CM	Groove



# WE ARE PART OF A GREAT ALLIANCE

---

HKL works in strong network of  
the LY-Holding with knowledge and  
experience for your success.

---

HKL is the specialist for rubber processing, as well as tyre curing and tyre bulding bladder production. As part of the LY-Holding, we work with a lot of experience and joint knowledge for your success. LY-Holding is the service partner for the industry. With German-Turkish roots, it is a world-class corporation. More than 1,400 specialists are in operation around the world – wherever our customers need us.

We focus on your success: We tackle new challenges and implement them quickly, flexibly and reliably. Our service solutions are tailored to your needs and support your processes. The LY-Holding, every company and every individual employee stands for that. We grow day by day – together with you.

## LY-Holding GmbH

### HKL Gummi- und Metallbearbeitungs GmbH

- » RUBBER METAL COMPONENTS AND INSTALLATION SERVICES  
Moulding and burr removing, tyre building and tyre curing bladders, installation and shipping for manifold products.

### LY Lang & Yüzer Otomotiv A. S.

- » SYNERGIES BETWEEN GERMANY AND TURKEY  
Services for rubber and metal handling and dry ice technology.

### LKY Wartungs- und Industrie-Service GmbH

- » PARTNER OF THE TYRE INDUSTRY  
Global Expertise in mould management and innovative business solutions.
- » INDUSTRIAL CLEANING AND MAINTANANCE  
On-site maintenance, operational safety and personal assistance.
- » SYSTEMATIC CLEANING FOR RETURNABLE CONTAINERS  
Your reliable partner for cleaning and sorting, storage and logistics.

### LKY Kältetechnik und Dienstleistungs GmbH

- » DRY ICE PRODUCTION AND BLASTING TECHNOLOGY  
Gentle cleaning and production of high-tech cooling agents.

### SKK Scholz Werbende Verpackungen GmbH

- » PACKAGING AND PRODUCT MARKETING SOLUTIONS  
Smart packaging design and point-of-sale marketing concepts.

**HKL Gummi- und Metallbearbeitungs GmbH**

---

**Leipziger Straße 13  
64711 Erbach**

**Tel.: +49 (0) 6163 71-3125  
Fax: +49 (0) 6163 71-3124**

---

**Mail: [info@hkl-bladder.de](mailto:info@hkl-bladder.de)  
Web: [www.hkl-bladder.de](http://www.hkl-bladder.de)**